

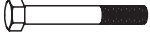





ASSEMBLY STEP 1

HARDWARE USED IN THIS STEP

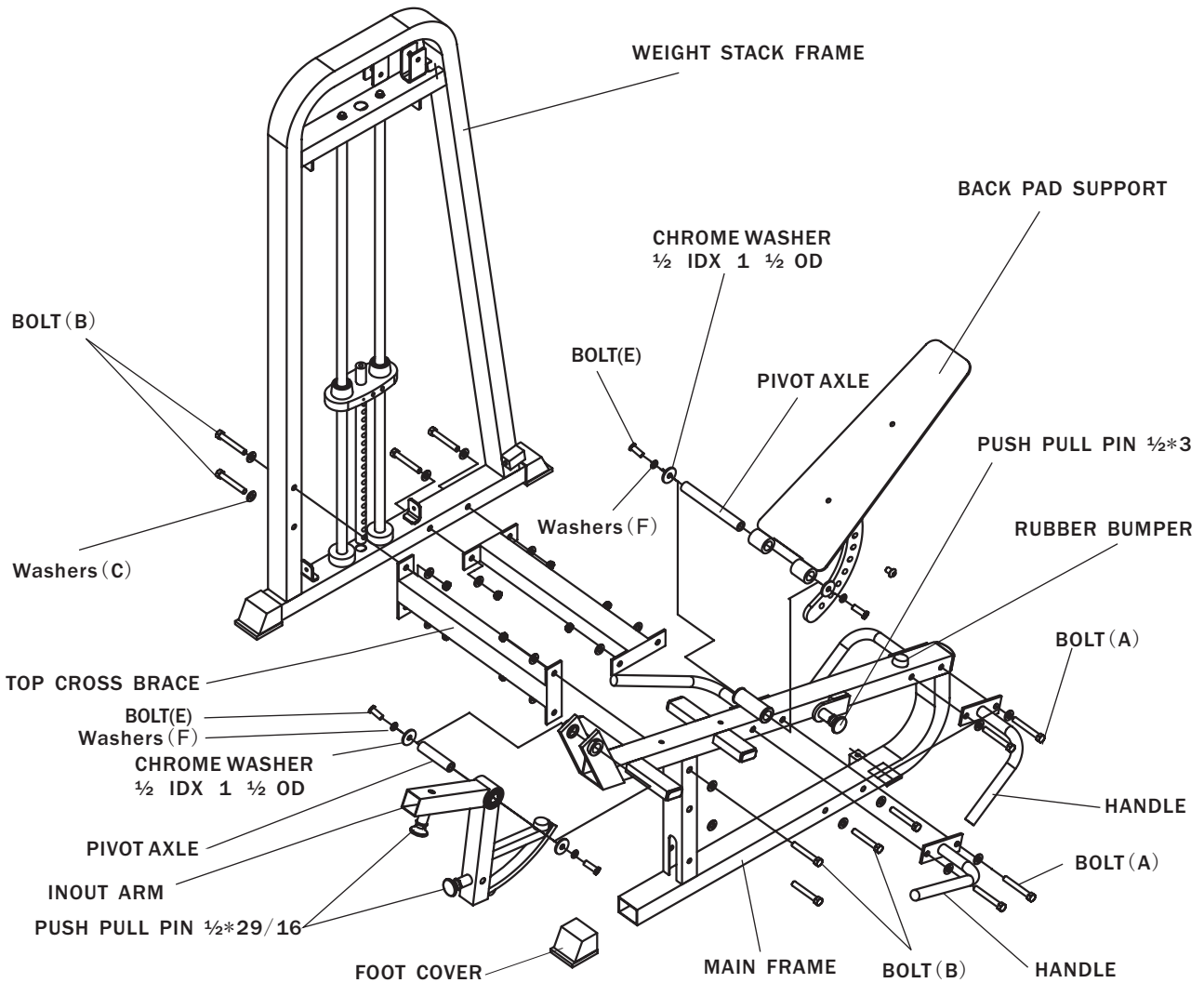

	
Bolts(A) QTY: 4	Nuts(D) QTY: 12
HBOLT 0.5-13 3.75	HJNUT 0.5-13
	
Bolts(B) QTY: 8	Washers(C) QTY: 24
HBOLT 0.5-13 3.5	FW 0.5
	
Bolts(E) QTY: 4	Washers(F) QTY: 4
HBOLT 0.5-13 1	LW 0.5
	
	CHROME WASHER
	1/2 IDX 1 1/2 OD
	QTY: 4

NOTE: During each assembly step, ensure that all bolts and nuts are in place and partially threaded in before completely any one bolt.

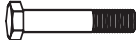

ASSEMBLY STEP 2

HARDWARE USED IN THIS STEP

			
Bolts(A) QTY:4	Bolts(B) QTY:2	Bolts(C) QTY:2	Washer(D) QTY:4
HX-SHCS 0.375-16 1.375	1.375-NHBOLT 0.375-16 2.75	HBOLT 0.375-16 1	FW 0.375

NOTE: During each assembly step, ensure that all bolts and nuts are in place and partially threaded in before completely any One

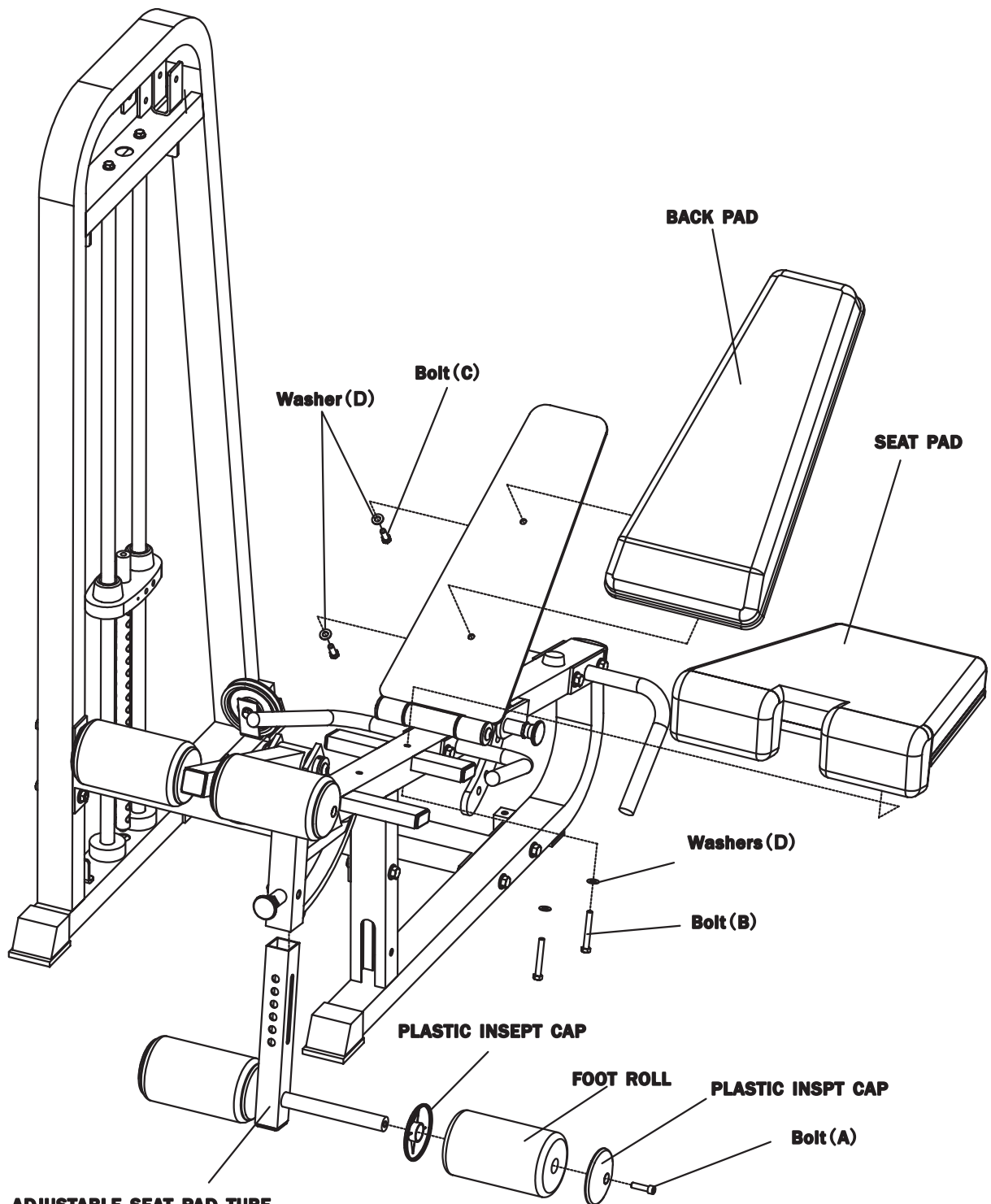

ADJUSTABLE SEAT PAD TUBE

ASSEMBLY STEP 3

HARDWARE USED IN THIS STEP

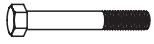

Bolts(A) QTY: 2
HBOLT 0. 375-16 2. 75



Washers(B) QTY: 2
FW 0. 375

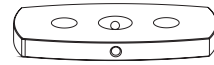

WEIGHT STACK (10LB)
QTY: 19

NOTE: During each assembly step, ensure that all bolts and nuts are in place and partially threaded in before completely any one bolt.

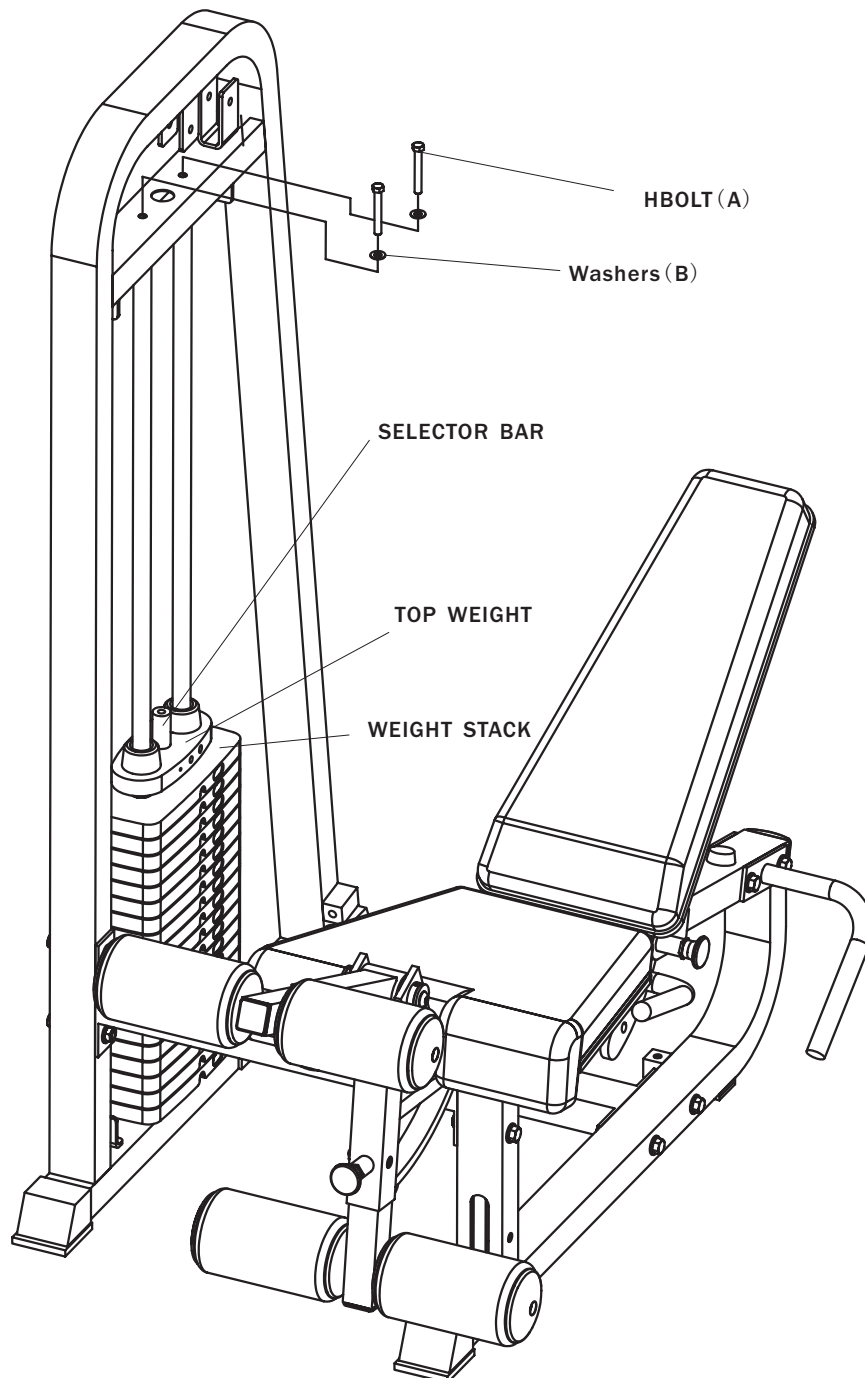

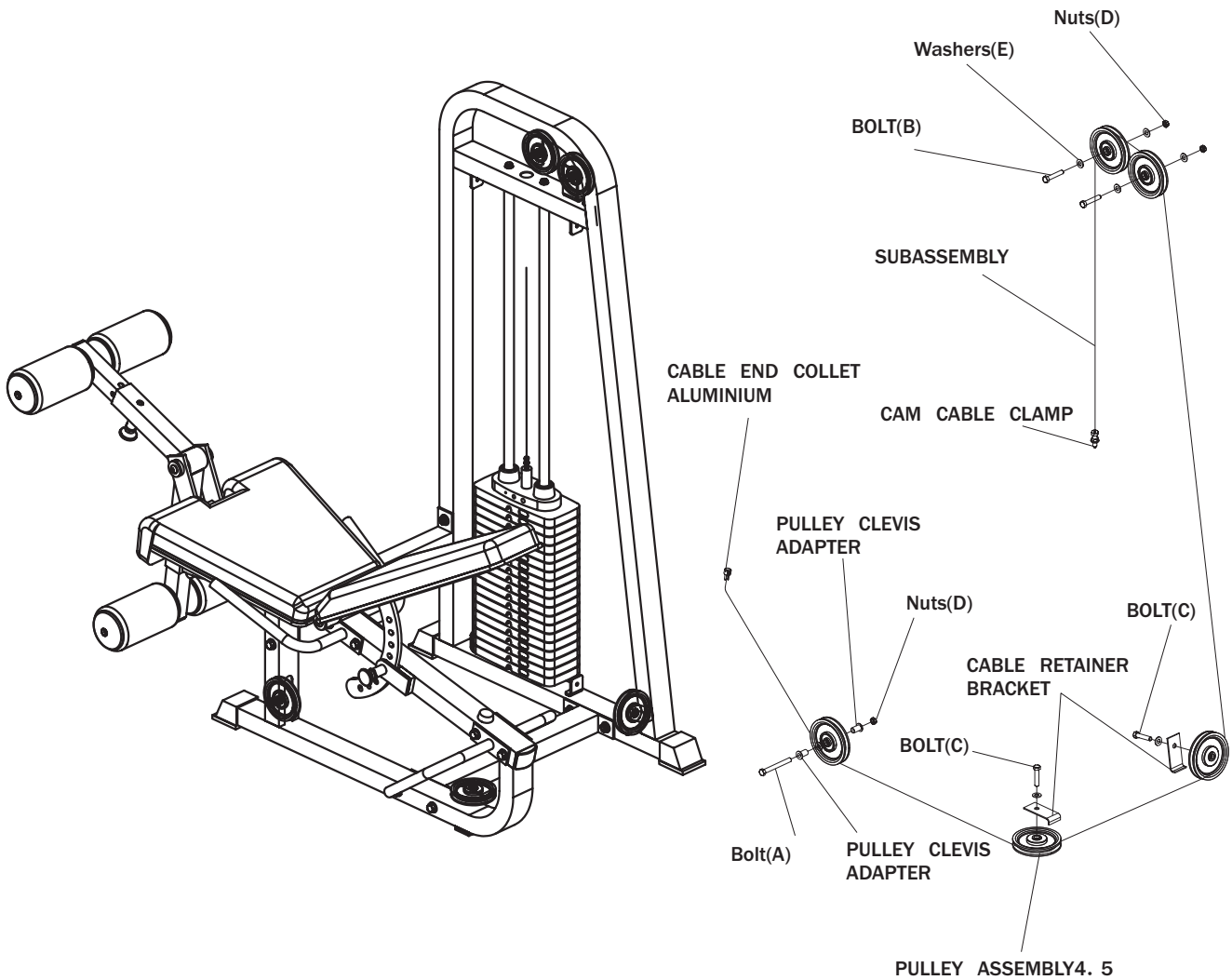

ASSEMBLY STEP 4

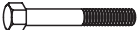

HARDWARE USED IN THIS STEP

Bolts(A) QTY: 1
 HBOLT 0. 375-16 3. 5

Bolts(B) QTY: 2
 HBOLT 0. 375-16 2

Bolts(C) QTY: 2
 HBOLT 0. 375-16 1. 75

Nuts(D) QTY: 3
 HJNUT 0. 375-16

Washers(E) QTY: 6
 FW 0. 375



ASSEMBLY STEP 5

HARDWARE USED IN THIS STEP



Bolts(A) QTY: 4
SBHCSCREW 0.315-18 0 75 HX-N



Bolts(B) QTY: 10
SBHCSCREW 0.25-20 0 315 HX-N



Nuts(C) QTY: 4
HNUT 0.315-18



Washers(D) QTY: 8
FW 0.315

NOTE: During each assembly step, ensure that all bolts and nuts are in place and partially threaded in before completely any one bolt.

