

STEP 1

NOTE: During each assembly step, ensure that all bolts and nuts are in place and partially threaded in before completely tightening any one bolt. Two people will be required to perform this procedure.

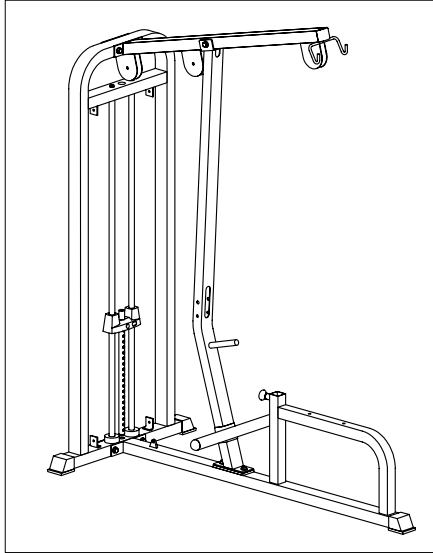

Above shows step 1 assembled and completed.

Part list of step 1

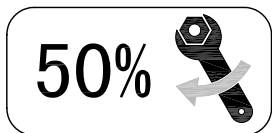
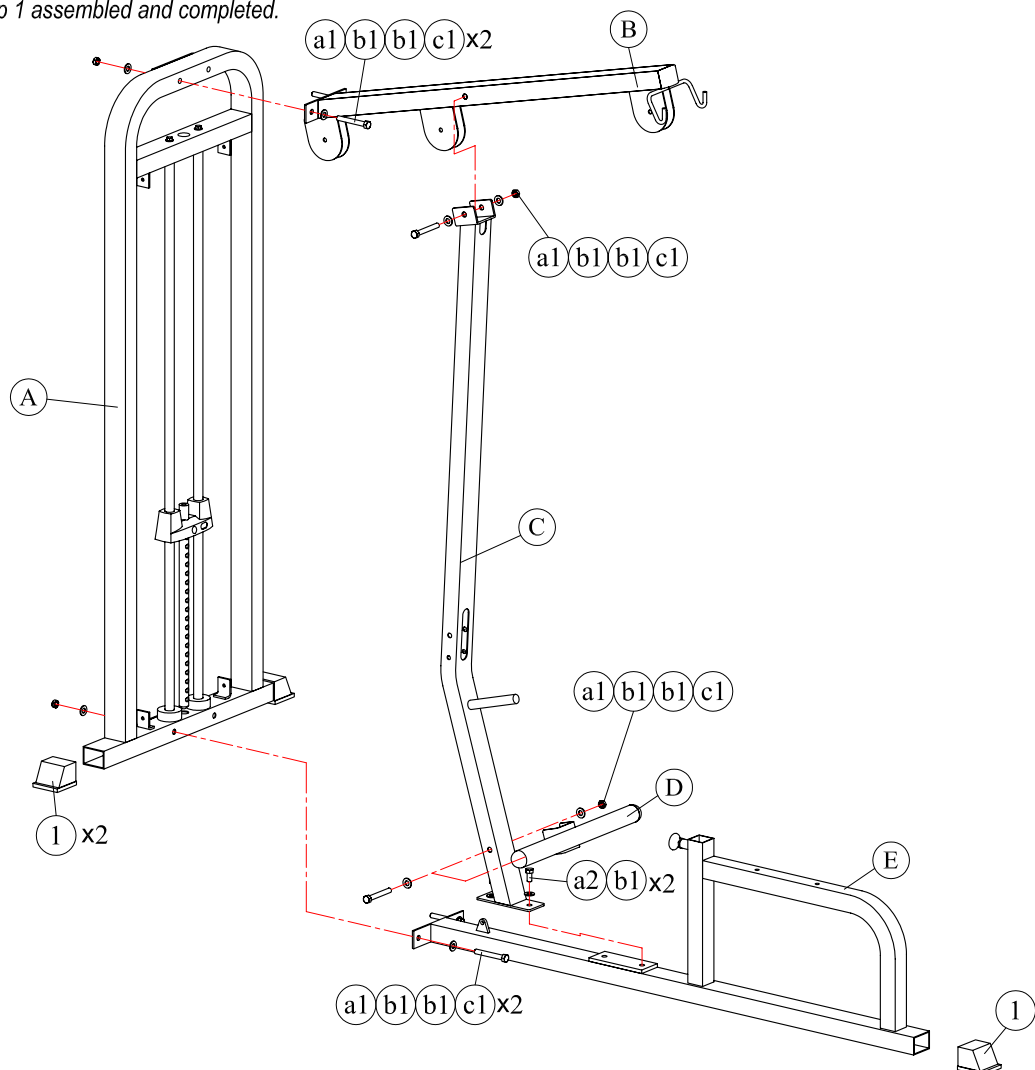

ITEM	DESCRIPTION	QTY
A	ASSY,WEIGHT SIDE FRAME	1
B	ASSY, TOP PULLEY TUBE	1
C	ASSY,FRONT UPRIGHT	1
D	ASSY,FOOT LEVER	1
E	ASSY,SEAT FRAME	1
1	FOOT COVER 2"x2.75"	3
a1	BOLT,HHCS,1/2"-13*3 3/4", L=95mm	6
a2	BOLT,HHCS,1/2"-13*1", L=25mm	2
b1	WASHER,FLAT,1/2"	14
c1	LOCK NUT 1/2"-13	6



STEP 2

NOTE: During each assembly step, ensure that all bolts and nuts are in place and partially threaded in before completely tightening any one bolt.

Part list of step 2

ITEM	DESCRIPTION	QTY	ITEM	DESCRIPTION	QTY
F	ASSY, TOP WEIGHT	1	a3	BOLT, HHCS, 3/8"-16*1 3/4", L=45mm	2
G	ASSY, LAT BAR	1	a4	BOLT, HHCS, 3/8"-16*2", L=50mm	3
H	ASSY, LOW ROW "V" BAR	1	a5	BOLT, HHCS, 3/8"-16*3 1/4", L=82mm	2
2	NYLON PULLEY ASSEMBLY(4.5")	6	b2	WASHER, FLAT, 3/8"	12
3	BUSHING (L=24)	2	c2	LOCK NUT 3/8"-16	7
4	DOUBLE PULLEY PLATE	2	1#		1
5	WEIGHT STACK	19	2#		1
6	SELECTOR PIN	1			
7	WEIGHT PLATE DECAL (10-200LBS)	1			
26	COIL CHAIN (4)	1			
27	TWO SNAP LINKS (Ø8)	1			

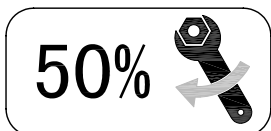
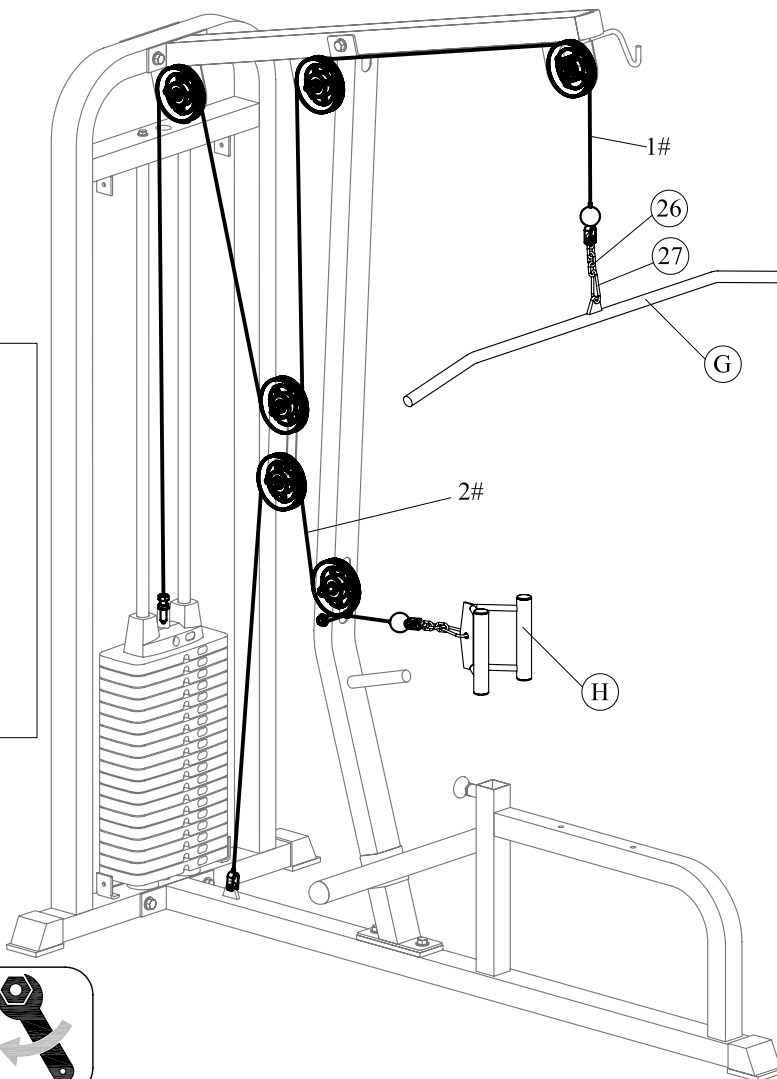
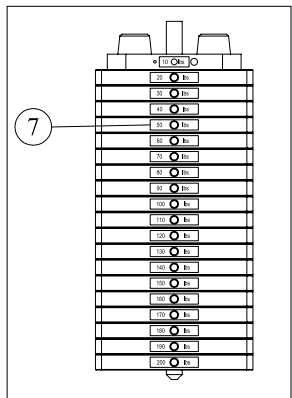
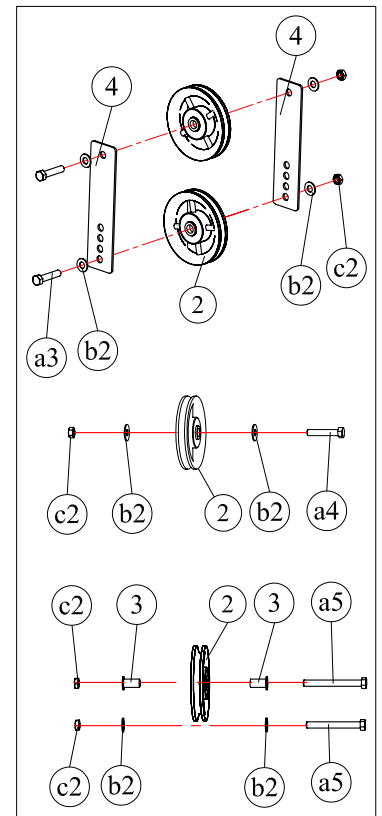
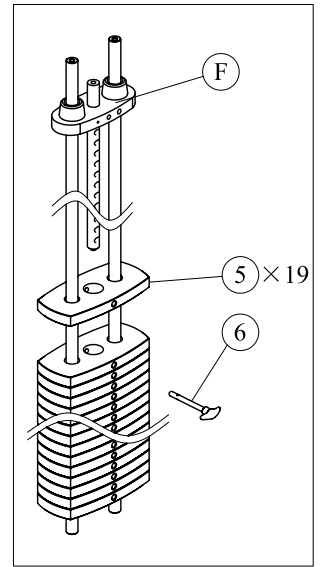

STEP 3

NOTE: During each assembly step, ensure that all bolts and nuts are in place and partially threaded in before completely tightening any one bolt.

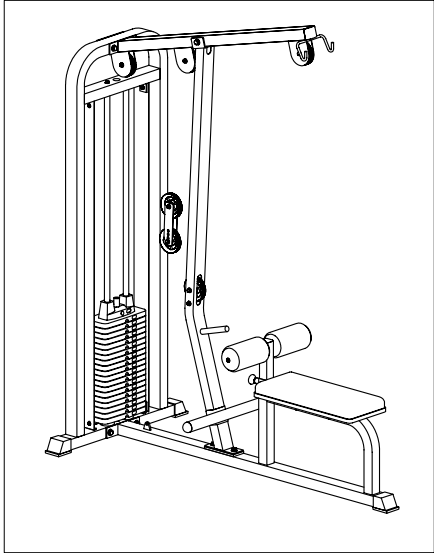

Above shows step 3 assembled and completed.

Part list of step 3

ITEM	DESCRIPTION	QTY
I	ASSY,ADJUSTING TUBE	1
8	PLASTIC INSERT CAP "B" 1 RD.	2
9	FOOT ROLL (Φ23*Φ120*200)	2
10	PLASTIC INSERT CAP "A" 1 RD.	2
11	AXLE(Ø 25*450)	1
12	SEAT PAD	1
a6	BOLT,SHCS,3/8"-16*1 3/8", L=35mm	2
a7	BOLT,HHCS,3/8"-16*2 3/4", L=70mm	2
a8	BOLT,BHCS,5/16"-18*3/4", L=16mm	4
b2	WASHER,FLAT,3/8"	2
b3	WASHER,FLAT,5/16"	8
c3	LOCK NUT 5/16"-18	4

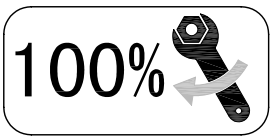
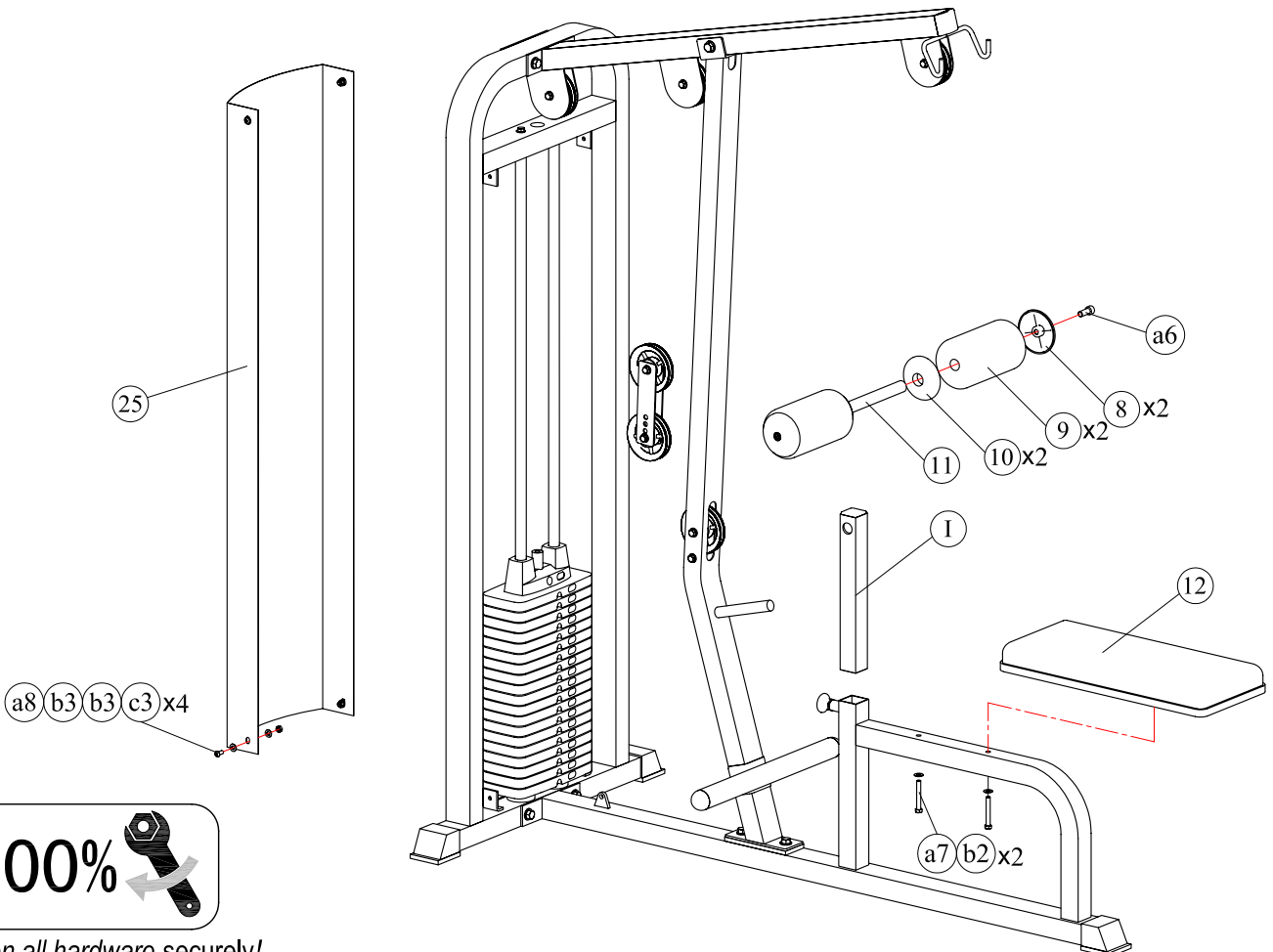

100% **Righten all hardware securely!**

PRE-ASSEMBLY

PART LIST:

ITEM	DESCRIPTION	QTY
A	ASSY,WEIGHT SIDE FRAME	1
B	ASSY, TOP PULLEY TUBE	1
C	ASSY, FRONT UPRIGHT	1
D	ASSY, FOOT LEVER	1
F	ASSY, TOP WEIGHT	1

A.ASSY,WEIGHT SIDE FRAME
F.ASSY, TOP WEIGHT

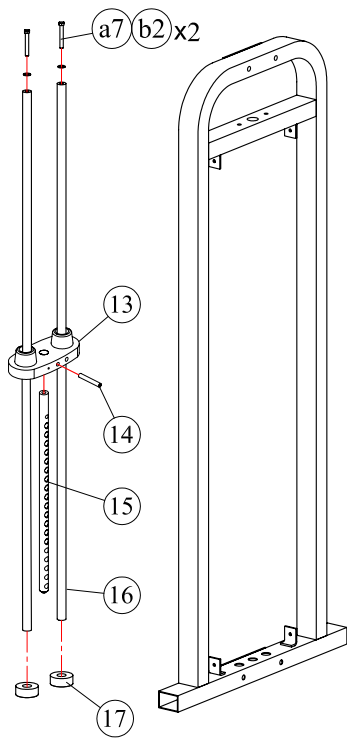

B. ASSY, TOP PULLEY TUBE

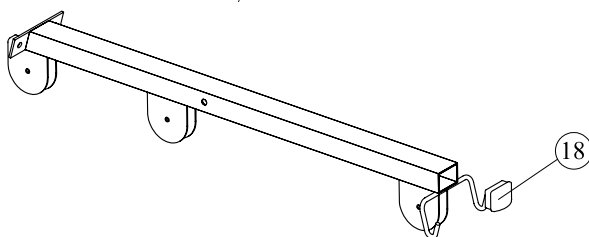

C.ASSY,FRONT UPRIGHT

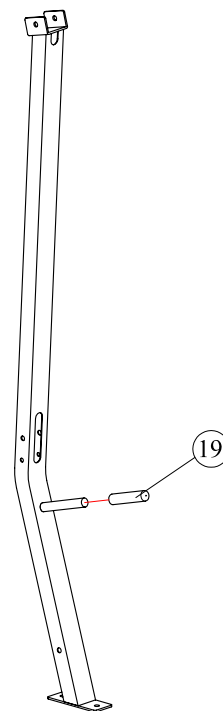

D.ASSY, FOOT LEVER

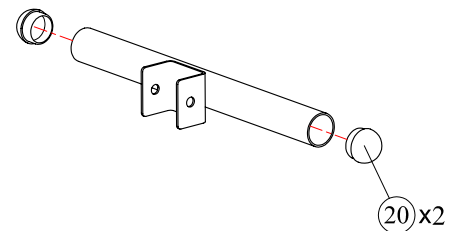

PRE-ASSEMBLY

PART LIST:

ITEM	DESCRIPTION	QTY
E	ASSY,SEAT FRAME	1
G	ASSY,LAT BAR	1
H	ASSY,LOW ROW "V" BAR	1
I	ASSY,ADJUSTING TUBE	1

E.ASSY,SEAT FRAME

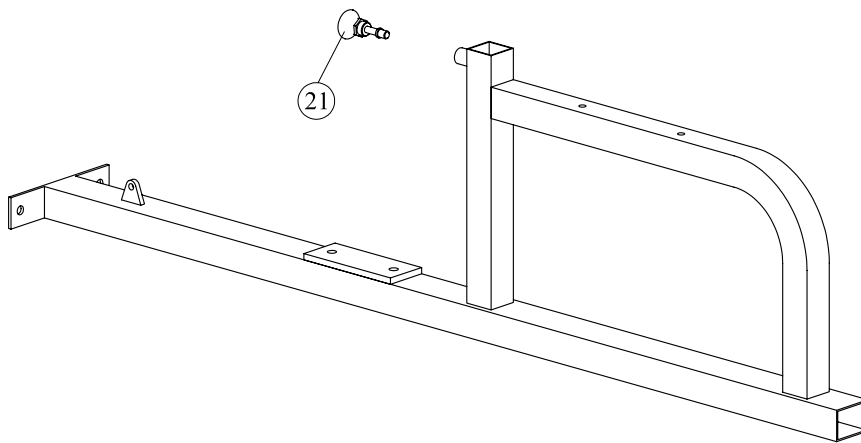

G.ASSY,LAT BAR

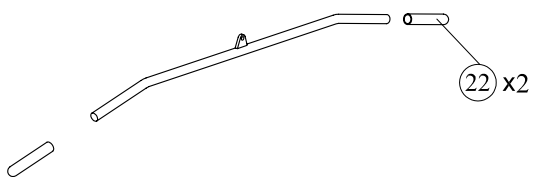

I.ASSY,ADJUSTING TUBE

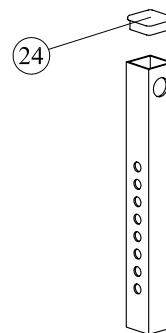

H.ASSY,LOW ROW "V" BAR

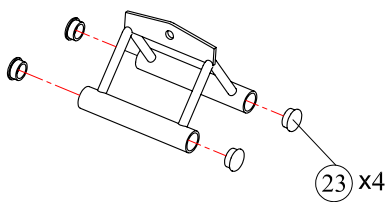

PART LIST 1



PART LIST:

ITEM	DESCRIPTION	QTY
1	FOOT COVER 2"x2.75"	3
2	NYLON PULLEY ASSEMBLY(4.5")	6
3	BUSHING (L=24)	2
4	DOUBLE PULLEY PLATE	2
5	WEIGHT STACK	19
6	SELECTOR PIN	1
7	WEIGHT PLATE DECAL (10-200LBS)	1
8	PLASTIC INSERT CAP "B" 1 RD.	2
9	FOOT ROLL (Φ23*Φ120*200)	2
10	PLASTIC INSERT CAP "A" 1 RD.	2
11	AXLE(Ø 25*450)	1
12	SEAT PAD	1
13	TOP WEIGHT	1
14	SPRING PIN(Ø10*70)	1
15	WEIGHT STACK PIN 19 HOLE	1
16	WEIGHT STACK GUIDE ROD(L=1600)	2
17	RUBBER DONUT	2
18	PLASTIC INSERT CAP 2x2.75	1
19	HANDLE (Ø24*130mm)	1
20	PLASTIC INSERT CAP DIA 2	2
21	PUSH PULL PIN (L=72,LOCKED)	1
22	HANDLE (Ø24*165mm)	2
23	PLASTIC INSERT CAP DIA 1.25	4
24	PLASTIC INSERT CAP 1.75SQ.	1
25	WEIGHT STACK SHIELD	1
26	COIL CHAIN (4)	1
27	TWO SNAP LINKS (Ø8)	1
A	ASSY,WEIGHT SIDE FRAME	1
B	ASSY, TOP PULLEY TUBE	1
C	ASSY,FRONT UPRIGHT	1
D	ASSY,FOOT LEVER	1
E	ASSY,SEAT FRAME	1
F	ASSY, TOP WEIGHT	1
G	ASSY,LAT BAR	1
H	ASSY,LOW ROW "V" BAR	1
I	ASSY,ADJUSTING TUBE	1





HARDWARE LIST:

ITEM	DESCRIPTION	QTY
a1	BOLT,HHCS,1/2"-13*3 3/4", L=95mm	6
a2	BOLT,HHCS,1/2"-13*1", L=25mm	2
a3	BOLT,HHCS,3/8"-16*1 3/4", L=45mm	2
a4	BOLT,HHCS,3/8"-16*2", L=50mm	3
a5	BOLT,HHCS,3/8"-16*3 1/4", L=82mm	2
a6	BOLT,SHCS,3/8"-16*1 3/8", L=35mm	2
a7	BOLT,HHCS,3/8"-16*2 3/4", L=70mm	4
a8	BOLT,BHCS,5/16"-18*3/4", L=16mm	4
b1	WASHER,FLAT,1/2"	14
b2	WASHER,FLAT,3/8"	16
b3	WASHER,FLAT,5/16"	8
c1	LOCK NUT 1/2"-13	6
c2	LOCK NUT 3/8"-16	7
c3	LOCK NUT 5/16"-18	4

CABLE LIST:

ITEM	DESCRIPTION	QTY
1#		1
2#		1

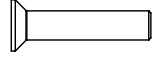
Hardware guide:

	BHCS-BUTTON HEAD CAP SCREW
	SHCS-SOCKET HEAD CAP SCREW
	FHCS-FLAT HEAD CAP SCREW
	HHCS-HEX HEAD CAP SCREW